



# Movable Glass Systems

[www.teamclassic.com](http://www.teamclassic.com)

One of the most awaited product by leading architects & interior designers ,now in INDIA by Team Classic





## OVERVIEW

### USES AND BENEFITS OF MOVABLE GLASS SYSTEMS

#### FOLDING SYSTEMS

GLITZY - Single Glazed Folding System

ELITE - Single Glazed Folding System

LUXE - Double Glazed Folding System

PLUSH - Double Glazed Folding System

#### VERTICAL SLIDING SYSTEM

EXTRAVAGANCE - Vertical Sliding System

#### TOP HANGING FOLDING SYSTEMS

EXPANDABLE - Top Hanging Folding System

OPULANCE - Top Hanging Folding System

#### SLIDING SYSTEMS

SPLENDOR - Single Glazed Flat Threshold Sliding System

GUSTO - Single Glazed High Threshold Sliding System

GLORYL - Double Glazed Flat Threshold Sliding System

ELEGENT - Double Glazed High Threshold Sliding System

#### ROOF SYSTEMS

ALLEVATION - Automatic Sliding Roof System

PLENTUDE - Fixed Veranda System

#### OVERVIEW OF THE SYSTEMS





## WHAT WE STAND FOR

- > **SUSTAINABILITY:** Our management, just-in-time workflow and consistency in our services are to provide the long term success, thanks to our in-depth knowledge of the industry.
- > **TRUST:** Understanding our customer needs, serving them at its best and keeping our promises is our core value above all.
- > **QUALITY AND DURABILITY:** As our quality management systems certified by ISO and CE labelling, as well as our materials by Qualanod, Qualicoat and Germany PfB test institute, we only use the best quality aluminium and accessories.
- > **WIDE RANGE OF CHOICES:** As being the main producer, we are able to serve you all the colours and options of accessories promptly.



- > **RIGHT DESIGN SOLUTIONS:** Our Austrian based R&D team offers you profound understanding and the best solutions for your complex project needs.
- > **INTERNATIONAL EXPERIENCE:** Having variety of nations in our work team and also serving to more than 20 countries in different continents, we understand different perspectives and speak your language.
- > **INNOVATION:** Our goal for the perfect synthesis of design and functionality, leads us always to develop both visually and architecturally superior solutions.

**CLASSIQUE**<sup>®</sup>  
GLAZINGS & CLADDINGS  
FRAMELESS GLASSES

## HOW WE SERVE YOU

- > **PROJECT SOLUTIONS:** A team composed of R&D experts, civil engineers and architects evaluates your project and offers the best solution according to your project needs. This also enables right and meaningful cost calculation.
- > **DESIGN:** Other than our current product portfolio, we are able to design custom made solutions/products according to your regional or project needs.
- > **CALCULATION SOFTWARE:** Our dealers are able to draw, calculate and price their projects easily with the AluArc software.
- > **CONTINUOUS SUPPORT AND TRAINING FOR OUR DEALERS:** Our team of experts follows up your project from a-to-z. We give on-site manufacturing and installation training for our products as well as online support to wherever you are.
- > **MANUFACTURING:** Quality and precision play a key role during production. All AluArc systems are manufactured with best quality raw materials with state-of-art machinery by trained teams following the quality management systems.
- > **ON-SITE INSTALLATION:** Additional to installation manuals and online support, we have installation teams to undertake your installation projects that can serve you in all countries.
- > **COMPLETION:** Short delivery times with maximum quality is a must for us. So we continuously monitor our work flow to ensure customer satisfaction in final customer acceptance.



## USES AND BENEFITS OF MOVABLE GLASS SYSTEMS



Enables to create extra spaces and enlarges your living / service spaces and creating shade when needed.



Protects from harsh weather conditions, dirt, noise etc. while providing thermal insulation.



Reduces heating/cooling expenses of the building by increased insulation and extends building life cycle by reduced corrosion.



Increases the security by their locking systems.



Easy to clean thanks to folding and sliding panels.



Silent and comfortable use with wheel system design.



Enables maximum transparency comparing to standard window systems.



Ability to glaze different angular spaces.

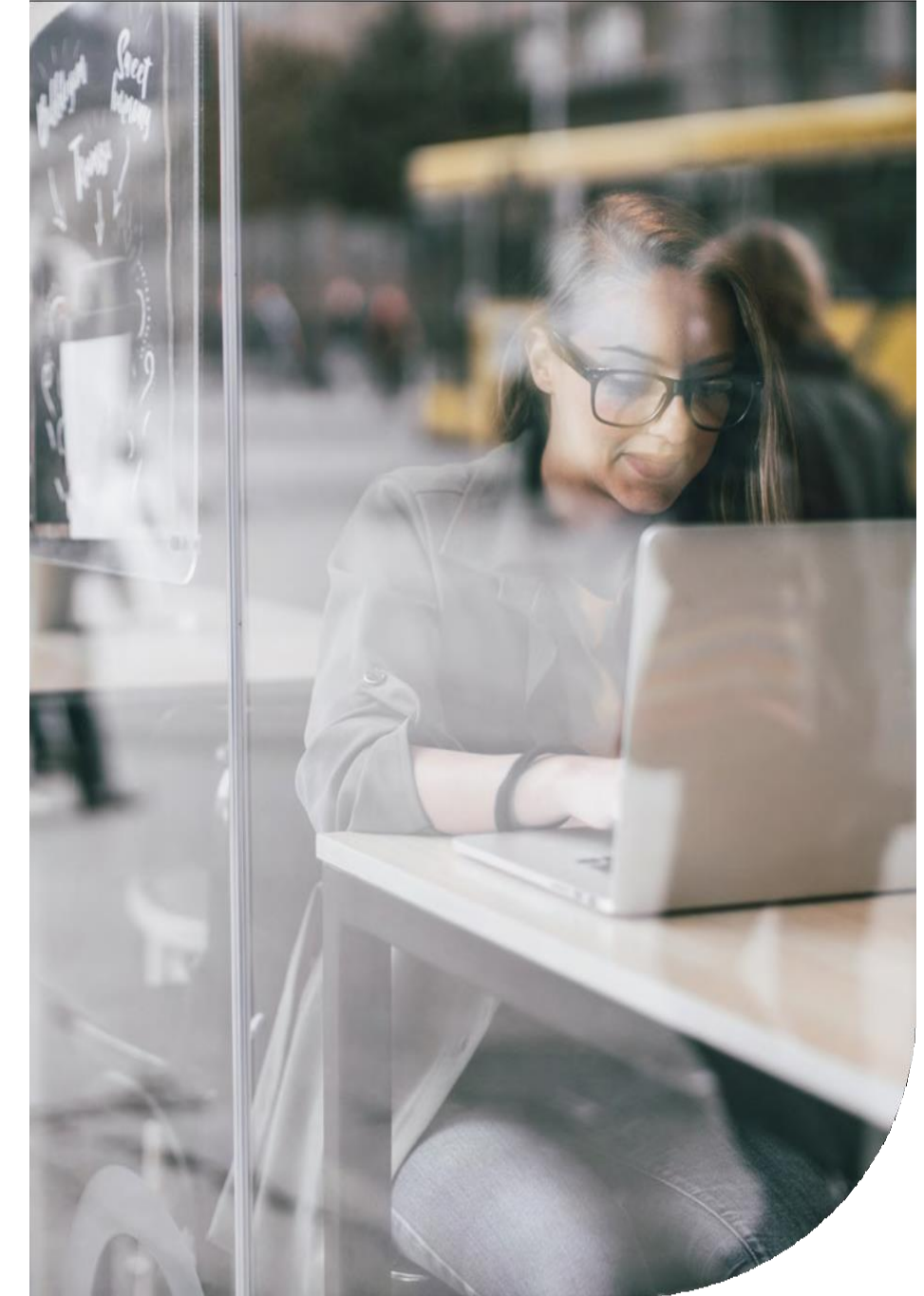





## FOLDING SYSTEMS



**CLASSIQUE**<sup>®</sup>  
GLAZINGS & CLADDINGS  
FRAMELESS GLASSES



# GLITZY

Single Glazed Folding System

Elegant design for balconies and glazing needs with threshold



Technical Details:	
Maximum system height	2200-2500 mm
Maximum panel width	600-650 mm
Glass thickness	8 mm and 10 mm
Glass type	Tempered/laminated
System operation	Sliding and folding
Profile colours (default)	Anodised, white, press
Profile cap colour options (default)	White, grey, black



## System Features:

- **Patented design that enables long years durability and comfort in use** especially suitable for glazing high balconies and threshold applicable spaces
- Wheel systems designed for **silent move**
- **Profile design which gives maximum transparency** and is robust at the same time
- Panel exit guide that closes automatically with panel movement makes easier usage with stores has **Utility Model Award**
- Effective water discharge from bottom rail
- Thanks to **double latched lock mechanism both on top and bottom rail**, enhanced security
- Ability to mount on every kind of space with angular panel caps
- Easy to mount wheel systems that has **Utility Model Award**
- Profile aesthetic that appeal to modern tastes beside their robust structure
- At bottom and at top 4 pieces of wheel systems at total
- Totally integrated, elegantly designed wall side aluminium profiles
- Enhanced insulation with extra wall side gaskets
- Aesthetic, different angular, high quality polyamide panel caps
- Enduring metal accessories





# ELITE

Single Glazed Folding System

Professional solution for high balconies and glazing needs with threshold



Technical Details:	
Maximum system height	3000-3200 mm
Maximum panel width	700-750 mm
Glass thickness	8 mm and 10 mm
Glass type	Tempered/laminated
System operation	Sliding and folding
Profile colours (in stock)	Anodised, white, press
Profile cap colour options (in stock)	White, grey, black



## System Features:

- **Patented design that enables long years durability and comfort in use** is especially suitable for glazing high balconies and threshold applicable spaces
- Panel exit guide that closes automatically with panel movement makes easier usage with stores has **Utility Model Award**
- Effective water discharge from bottom rail
- Thanks to **double latched lock mechanism both on top and bottom rail**, enhanced security
- Ability to mount on every kind of space with angular panel caps
- Easy to mount wheel systems that has **Utility Model Award**
- Profile aesthetics that appeal to modern tastes beside their robust structure
- At bottom and at top 4 pieces of wheel systems at total
- Totally integrated, elegantly designed wall side aluminium profiles
- Enhanced insulation with extra wall side gaskets
- Aesthetic, different angular, high quality polyamide panel caps
- Enduring metal accessories



# LUXE

Double Glazed Folding System

Comfort of double glass for balconies and glazing needs with threshold



Technical Details:	
Maximum system height	2200-2500 mm
Maximum panel width	600-650 mm
Glass thickness	4+20+4, 28 mm thick double glass
Glass type	Tempered/laminated
System operation	Sliding and folding
Profile colours (in stock)	Anodised, white, press
Profile cap colour options (in stock)	White, grey, black



## System Features:

- **Thermal insulation advantage** especially suitable for glazing high balconies and threshold applicable spaces
- **Applicable to 90° and 135°** type corners with angular panel profiles
- **Maximum insulation** due to inner magnets and in between gaskets of panels
- Aesthetic design that appeal to modern tastes in panel and rail profiles, beside their robust structure
- Wheel systems designed for **silent move**
- Panel exit guide that closes automatically with panel movement makes easier usage with stores has **Utility Model Award**
- Effective water discharge from bottom rail
- Easy to mount wheel systems that has **Utility Model Award**
- At bottom and at top 4 pieces of wheel systems at total
- Enhanced insulation with extra wall side gaskets
- Enduring metal accessories

**CLASSIQUE**<sup>®</sup>  
GLAZINGS & CLADDINGS  
FRAMELESS GLASSES





# PLUSH

Double Glazed Folding System

The only double glazed system that has self-locking mechanism in folding panels



Technical Details:	
Maximum system height	3000-3200 mm
Maximum panel width	700-750 mm
Glass thickness	4+20+4, 28 mm thick double glass
Glass type	Tempered/laminated
System operation	Sliding and folding
Profile colours (in stock)	Anodised, white, bronze
Profile cap colour options (in stock)	White, black, grey



## System Features:

- **Self-locking mechanism in open sashes**
- **Thermal insulation advantage** especially suitable for glazing high balconies and threshold applicable spaces
- **Stronger panel structure**
- **Aesthetic and invisible locking mechanism** that is adjustable to desired height
- **Applicable to 90° and 135°** type corners with angular panel profiles
- **Maximum insulation** due to inner magnets and in between gaskets of panels
- Aesthetic design that appeal to modern tastes in panel and rail profiles, beside their robust structure
- Wheel systems designed for **silent move**
- Panel caps that aesthetically integrate with panel frame
- Panel exit guide that closes automatically with panel movement makes easier usage with stores has **Utility Model Award**
- Effective water discharge from bottom rail
- At bottom and at top 4 pieces of wheel systems at total
- Totally integrated, elegantly designed wall side aluminium profiles
- Enhanced insulation with extra wall side gaskets
- Enduring metal accessories



**CLASSIQUE**<sup>®</sup>  
GLAZINGS & CLADDINGS  
FRAMELESS GLASSES





## VERTICAL SLIDING SYSTEM



**CLASSIQUE**<sup>®</sup>  
GLAZINGS & CLADDINGS  
FRAMELESS GLASSES



# EXTRAVAGANCE

Vertical Sliding System

Where endurance  
meets aesthetics

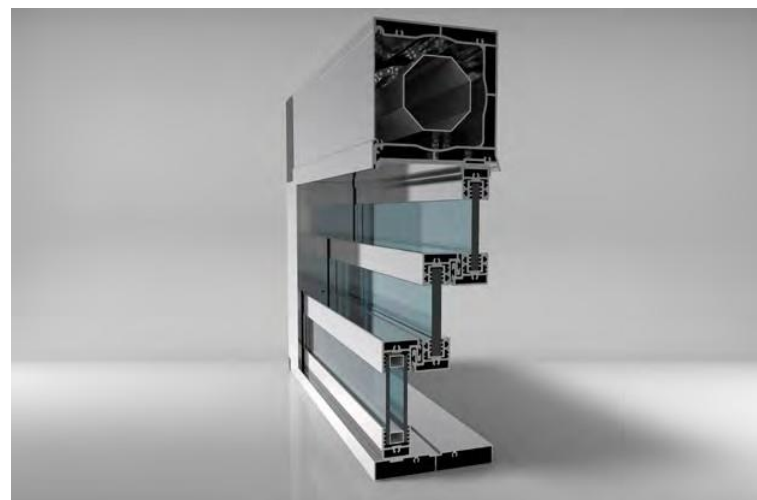

Technical Details:	
Maximum system height	3000 mm
Maximum panel width	4000 mm
Glass thickness	22 mm thick double glass
Glass type	Tempered/laminated
System operation	Vertical sliding, stacking at top or at the bottom
Profile colours (in stock)	Press
Profile cap colours (in stock)	Black, grey



## System Features:

- System allows you to create open or closed spaces without occupying extra space and allows effective ventilation without a security risk
- **Strong chains of moving system** ensures highest security and long years durability with minimal maintenance
- **Easy manufacturing** thanks to easily inserted parts of the mechanism that doesn't require screwing
- Panel profiles that allow using **single or double glass**
- Interlocking structure of panel profiles and insulation brushes that are used in all sides of the system ensure **highest insulation**
- Robust profile structure, 3 panel design and interlocking between the panels, allow highest wind resistance and security
- **Aesthetic caps of track profile** and elegant design of track and panel profiles, allow maximum transparency
- Photocell mechanism that increase the usage security
- **Maximum stability of panels** even in case of power outage
- 120 N- 275 kg strong motor mechanism that is hidden at top track block, ensures smooth and well-proportioned movement of panels
- Panels can either collect at top to create a non-threshold walk-through area or at the bottom to create a balustrade







## TOPHANGING FOLDING SYSTEMS



**CLASSIQUE**<sup>®</sup>  
GLAZINGS & CLADDINGS  
FRAMELESS GLASSES



# EXPANDABLE

TopHanging Folding System

Comfort, smoothness and economic solution for non-threshold glazing



Technical Details:	
Maximum system height	3000-3500 mm
Maximum panel width	1000 mm
Glass thickness	8 mm and 10 mm
Glass type	Tempered/laminated
System operation	Sliding and folding, stacking at a parking bay
Profile colours (in stock)	Anodised, press
Profile cap colour options (in stock)	Black



## System Features:

- **No tackling, no uneasiness of panel movements** thanks to single piece design of parking base
- Long years of comfortable usage even in the highest glazings thanks to **high robustness with glass pins and strong profiles**
- Especially suitable for inner and outer spaces like cafes, malls, offices that requires no threshold on the floor and need easiness to partition the spaces
- Robust wheel systems that enables smooth and silent movement of panels
- Bottom and top panel brushes that minimises the penetration of dust, water etc.
- Maximum security with hidden, in-between panels, to floor locking pins
- Chrome plated wheel systems and high quality poliamid profile caps
- **Easy mounting** with adjustable hinge system
- Chic design of side frame profiles

**CLASSIQUE**<sup>®</sup>  
GLAZINGS & CLADDINGS  
FRAMELESS GLASSES





# OPULENCE

TopHanging Folding System

The smoothest sliding top hanging system



Technical Details:	
Maximum system height	4500 mm
Maximum panel width	1200 mm
Glass thickness	10 mm
Glass type	Tempered/laminated
System operation	Sliding and folding, stacking at a parking bay
Profile colours (in stock)	Anodised
Profile metal cap colour options (in stock)	Anodised, chrome plated, electrostatic powder painted



## System Features:

- Draw even the highest panels with a single hand
- No tackling, no uneasiness of panel movements thanks to single piece design of parking base
- Long years of comfortable usage even in the highest glazings thanks to **high robustness with glass pins and strong profiles**
- Especially suitable for inner and outer spaces like cafes, malls, offices that requires no threshold on the floor and need easiness to partition the spaces
- **Special parking bay designs** for different spaces:
  - o Parking bays parallel to track
  - o Parking bays perpendicular to track
  - o Multi integrated parking bays
- Ability to apply **central wheeled panel systems without a parking bay**
- Ability to apply with panel walls instead of glass
- Robust wheel systems that enables smooth and silent movement of panels
- Bottom and top panel brushes that minimises the penetration of dust, water etc
- Maximum security with hidden, in-between panels, to floor locking pins
- Wheel systems enhanced against corrosion and zamak alloy profile caps
- Easy mounting with adjustable hinge system
- Chic design of side frame profiles





## SLIDING SYSTEMS



**CLASSIQUE**<sup>®</sup>  
GLAZINGS & CLADDINGS  
FRAMELESS GLASSES



# SPLENDOR

single Glazed Flat Threshold Sliding System

Comfortable passes in floor  
to ceiling glazing

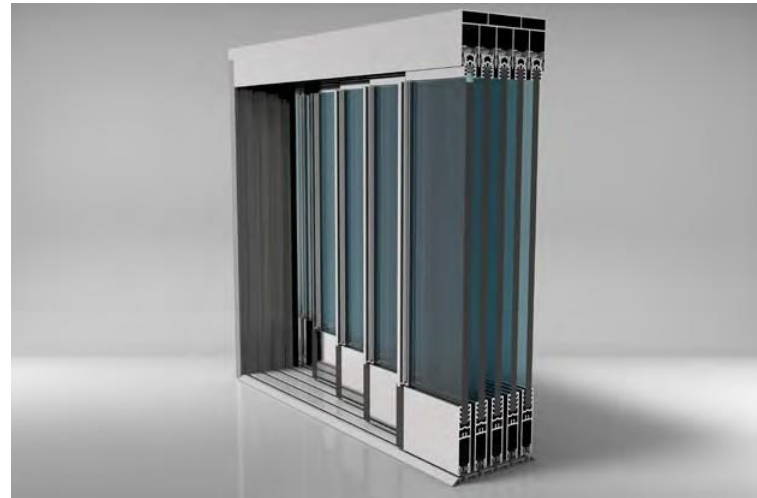

Technical Details:	
Maximum system height	2900 mm
Maximum panel width	1000 mm
Glass thickness	8 mm
Glass type	Tempered/laminated
System operation	Horizontal slide in consecutive tracks
Profile colours (in stock)	Anodised, press
Profile cap colour options (in stock)	Grey, black



## System Features:

- **Maximum usage area** due to non-hinged motion of panels
- Especially suitable for winter-gardens, cafes, shops etc. for a **smooth entrance/exit**
- **Special design for corners** so easy to apply in different designs with great insulation
- Interlocking structure of panel profiles allow enhanced security and insulation at the same time
- Top and bottom wheel systems with maximum **silence and comfort**
- Adjustable wheel systems carrying from the bottom
- **Steady movement** with cross design wheel system
- Full security with bottom profile locking panel locks
- Aesthetic, high quality polyamide panel caps
- Enduring metal accessories





# GUSTO

Single Glazed High Threshold Sliding System

Practical solution for space partitions and floor to ceiling glazing with sliding panels

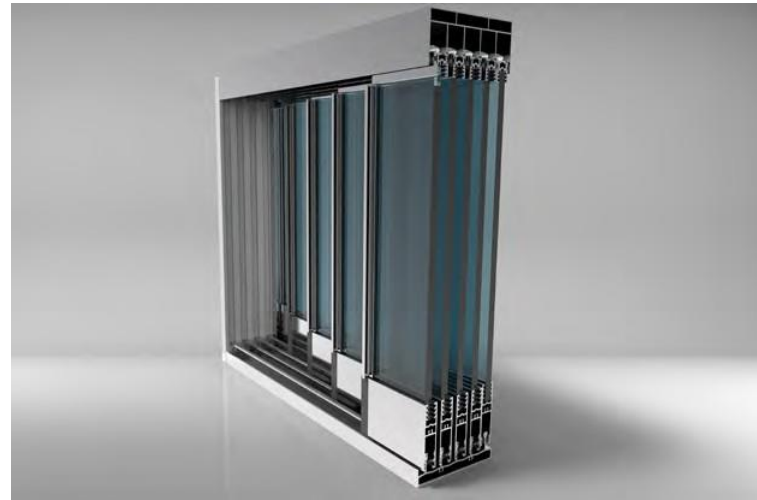

Technical Details:	
Maximum system height	2900 mm
Maximum panel width	1000 mm
Glass thickness	8 mm
Glass type	Tempered/laminated
System operation	Horizontal slide in consecutive tracks
Profile colours (in stock)	Anodised, press
Profile cap colour options (in stock)	Grey, black



## System Features:

- **Maximum usage area** due to non-hinged motion of panels
- Suitable for space partitioning, also ideal for entrances
- **Special design for corners** so easy to apply full system with great insulation
- Grab rails designed for easy use and enhanced security minimises water, dust etc. penetration at the same time
- Top and bottom wheel systems with maximum **silence and comfort**
- Bottom carriage, adjustable wheel systems
- Steady movement with cross design wheel system
- Full security with bottom profile locking panel locks
- **Efficient and chic design of water discharge** system at bottom rail
- Aesthetic, high quality polyamide panel caps
- Enduring metal accessories

**CLASSIQUE**<sup>®</sup>  
GLAZINGS & CLADDINGS  
FRAMELESS GLASSES



# GLORY

Double Glazed Flat Threshold Sliding System

Privilege of enhanced insulation in flat threshold sliding system

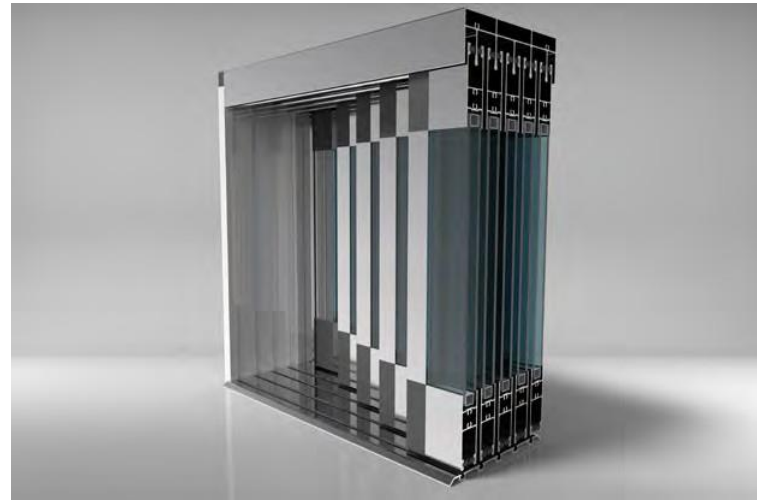

Technical Details:	
Maximum system height	3200 mm
Maximum panel width	1000 mm
Glass thickness	20 mm double glass
Glass type	Tempered/laminated
System operation	Horizontal slide in consecutive tracks
Profile colours (in stock)	Anodised, press
Profile cap colour options (in stock)	Grey, black



## System Features:

- Spring loaded and adjustable top and bottom wheels enables **long years durability and comfort**
- Topwheels that prevents panels coming out, also enables **smooth and steady movement**
- Panel side profiles designed to ensure maximum insulation
- **Special design for corners** so easy to apply in different designs with great insulation
- **Practical manufacturing** thanks to easily inserted assemble apparatus
- **Full security** with hidden and aesthetic panel lock
- Enduring metal accessories
- Aesthetic, high quality polyamide panel caps

**CLASSIQUE**<sup>®</sup>  
GLAZINGS & CLADDINGS  
FRAMELESS GLASSES





# ELEGENT

Double Glazed High Threshold Sliding System

Enjoy the sliding system  
with enhanced insulation

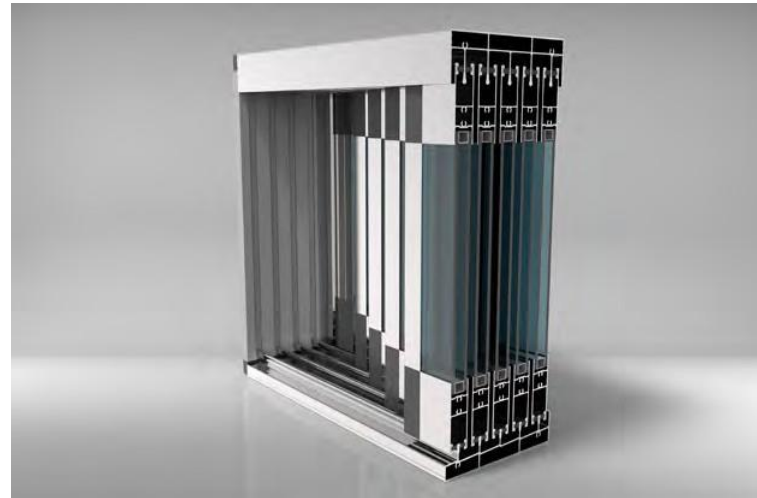

Technical Details:	
Maximum system height	3200 mm
Maximum panel width	1000 mm
Glass thickness	20 mm double glass
Glass type	Tempered/laminated
System operation	Horizontal slide in consecutive tracks
Profile colours (in stock)	Anodised, press
Profile cap colour options (in stock)	Grey, black



## System Features:

- Spring loaded and adjustable top and bottom wheels *enables long years durability and comfort*
- Top wheels that *prevents panels coming out*, also enables a *smooth and steady movement*
- Panel side profiles designed to ensure maximum insulation
- **Special design for corners** so easy to apply in different designs with great insulation
- **Practical manufacturing** thanks to easily inserted assemble apparatus
- **Full security** with hidden and aesthetic panel lock
- Enduring metal accessories
- Aesthetic, high quality polyamide panel caps



**CLASSIQUE**<sup>®</sup>  
GLAZINGS & CLADDINGS  
FRAMELESS GLASSES





## ROOF SYSTEMS



**CLASSIQUE**<sup>®</sup>  
GLAZINGS & CLADDINGS  
FRAMELESS GLASSES



# ALLEVIATION

Automatic Sliding Roof System

Stylish sliding roof solution  
with wide scope of customisation

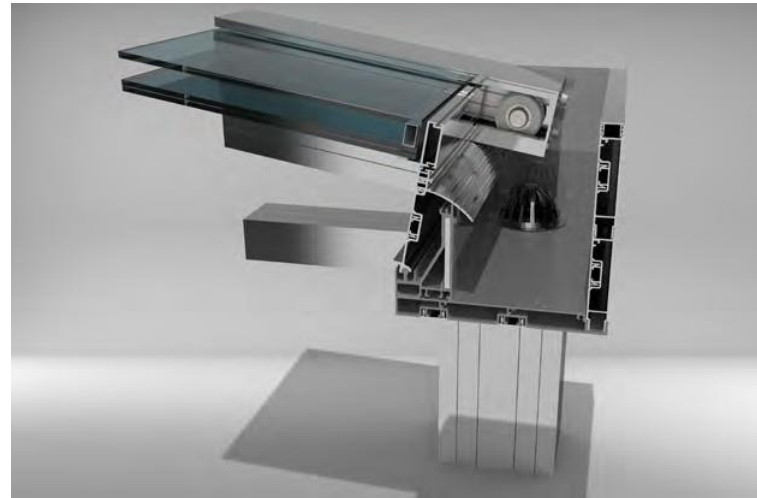

Technical Details:	
Panel width	1200 mm to 1350 mm
Panel length	6000 mm
Glass thickness	10 to 38 mm double glass
Glass type	Tempered/laminated
Roof Pitches	0° to 25°
System operation	Sliding
Profile colours (default)	Press



## System Features:

- **Patented system** that enables long years durability and comfort in use with a minimal designed integrated units
- Especially suitable for terraces, garden enclosures, winter garden roofs, pool enclosures, restaurants and smoking rooms
- System is composed of sliding modules that move over each other and stack under the fixed part.
- **%100 water and air tightness** thanks to its unique profile design
- Cost reduction through **high modular design and short installation times**
- **Provides wall solutions** at the same time
- Strong motor provides uniform, reliable movement of the sliding and customised opening speeds
- Options to **use with glass, polycarbonate or other panel systems**
- Concealed guttering that creates minimal and contemporary finish
- A completely modular construction enables you to start with the basic roof and then **add shading products, lighting and additional heating**
- Fully adaptation with vertical movable glass systems to convert into a full glass room
- Optional mounting **as roof overhang or as a free standing system without a need of steel construction**
- Corrosion resistant metal accessories and stainless steel screws

**CLASSIQUE**<sup>®</sup>  
GLAZINGS & CLADDINGS  
FRAMELESS GLASSES



# PLENITUDE

Fixed Veranda System

Functional and elegant veranda solution

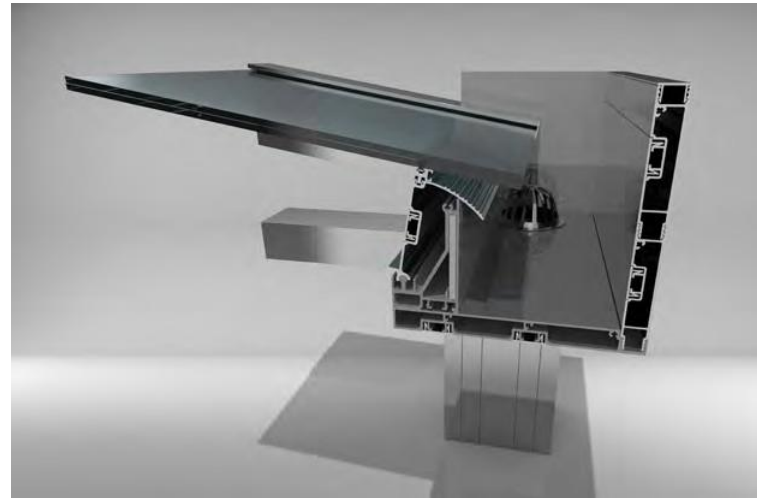

Technical Details:	
Panel width	1000 mm
Panel length	6000 mm
Glass thickness	4 mm to 16 mm laminated glass
Glass type	Tempered/laminated
Roof Pitches	0° to 25°
System operation	Fixed
Profile colours (default)	Press



## System Features:

- **Patented system** that enables long years durability and comfort in use with a minimal designed integrated units
- **%100 water and air tightness** thanks to its unique profile and gasket design
- Cost reduction through **high modular design and short installation times**
- Options to use with glass, polycarbonate or other panel systems
- Concealed guttering that creates minimal and contemporary finish
- **Provides wall solutions** at the same time
- A completely modular construction enables you to start with the basic roof and then **add shading products, lighting and additional heating**
- Fully adaptation with vertical movable glass systems to convert into a full glass room
- Optional mounting **as roof overhang or as a free standing system without a need of steel construction**
- Corrosion resistant metal accessories and stainless steel screws



**CLASSIQUE**<sup>®</sup>  
GLAZINGS & CLADDINGS  
FRAMELESS GLASSES



## OVERVIEW OF THE SYSTEMS

	GLITZY	ELITE	LUXE	PLUSH	EXTRAVAGANCE	EXPANDABLE	OPULANCE	SPLENDOR	GUSTO	GLORY	ELEGENT	ALLEVIATION	PLENITUDE	
	Single Glazed Folding System	Single Glazed Folding System	Double Glazed Folding System	Double Glazed Folding System	Vertical Sliding System	TopHanging Folding System	TopHanging Folding System	Single Glazed Flat Threshold Sliding System	Single Glazed High Threshold Sliding System	Double Glazed Flat Threshold Sliding System	Double Glazed High Threshold Sliding System	Automatic Sliding Roof System	Fixed Veranda System	
Dimensions	System Height	2200 mm-2500 mm	3000 mm-3200 mm	2200 mm-2500 mm	3000 mm-3200 mm	3000 mm	3000 mm-3500 mm	4500 mm	2900 mm	2900 mm	3200 mm	3200 mm	-	-
	Panel Width	620-650 mm	700-750 mm	620-650 mm	700-750 mm	4000 mm	1000 mm	1200 mm	1000 mm	1000 mm	1000 mm	1000 mm	1000 mm	1200 mm-1350 mm
System Operation	Sliding in one track and stacking at sides	Sliding in one track and stacking at sides	Sliding in one track and stacking at sides	Sliding in one track and stacking at sides	Vertical sliding and stacking at top or at the bottom	Sliding in one track and stacking at a parking bay	Sliding in one track and stacking at a parking bay	Horizontal slide in consecutive tracks	Horizontal slide in consecutive tracks	Horizontal slide in consecutive tracks	Horizontal slide in consecutive tracks	Horizontal slide in consecutive tracks	Horizontal slide in consecutive tracks	Fixed
Glass Type	Tempered/ Laminated	Tempered/ Laminated	Tempered/ Laminated	Tempered/ Laminated	Tempered/ Laminated	Tempered/ Laminated	Tempered/ Laminated	Tempered/ Laminated	Tempered/ Laminated	Tempered/ Laminated	Tempered/ Laminated	Tempered/ Laminated	Tempered/ Laminated	Tempered/ Laminated
Glass Thickness	8 mm & 10 mm	8 mm & 10 mm	28 mm Double Glass	28 mm Double Glass	22 mm Double Glass	8 mm & 10 mm	10 mm	8 mm	8 mm	20 mm Double Glass	20 mm Double Glass	4 mm to 16 mm Double Glass	10 mm to 38 mm	
In stock profile colours	Anodised, white, press	Anodised, white, press	Anodised, white, press	Anodised, white, press	Press	Anodised, press	Anodised, press	Anodised, press	Anodised, press	Anodised, press	Anodised, press	Press	Press	
In stock accessory colours	Grey, black, white	Grey, black, white	Grey, black, white	Grey, black, white	Grey, black.	Black	Anodised, electrostatic powder painted	Grey, black.	Grey, black.	Grey, black.	Grey, black.	Anodised, electrostatic powder painted	Anodised, electrostatic powder painted	



“TRANSPARENCY  
WITHOUT  
LIMITATIONS...”



**CLASSIQUE**<sup>®</sup>  
GLAZINGS & CLADDINGS  
FRAMELESS GLASSES





**CLASSIQUE**<sup>®</sup>  
GLAZINGS & CLADDINGS  
FRAMELESS GLASSES



**CLASSIQUE**<sup>®</sup>  
GLAZINGS & CLADDINGS  
FRAMELESS GLASSES